

NAHUI

User manual

High Voltage Energy Storage System

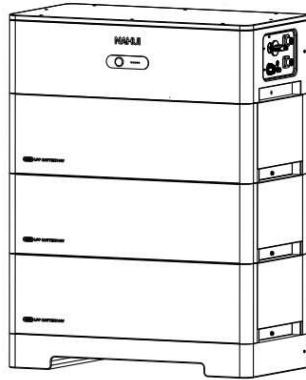

NHS-1Y10K
NHS-1Y15K
NHS-1Y20K
NHS-1Y25K
NHS-1Y30K
NHS-1Y35K
NHS-1Y40K

The picture is for reference only, subject to the actual object.
Different versions have slightly different.

Version1.0 Date:03.2024













Contents

1. Symbol Description	3
2. Safety Precautions.....	4
2.1 Before Connecting	4
2.2 In Using	5
2.3 Storage and installation environment	5
2.4 Battery performance (based on cell temperature).....	5
3. Introduction.....	6
3.1 Features	6
3.2 Specification.....	7
3.3 Equipment interface instruction	8
3.4 Monitoring	9
4. Safe Handling of Lithium-iron ESS Batteries Guide	15
4.1 Solution Diagram.....	15
4.2 Danger Label	16
4.3 Tool	17
4.4 Safety Gear.....	17
5. Installation and operation.....	18
5.1 Package items	18
5.2 Installation Location.....	18
5.3 Installation Direction.....	19
5.4 Installation Clearances and Angle.....	20
5.5 Installation Steps.....	21
5.6 System turns on	29
5.7 System turns off.....	30
6. iErgon APP	311
6.1 Overview	31
6.2 Download and install APP (Customer&Installer)	31
6.3 Apply for an account (Installer).....	32
6.4 Register account (Customer).....	32
6.5 Create Stations and bind devices (Installer).....	33
6.6 Configure WiFi (Customer&Installer).....	34
7. Emergency Situations	36
7.1 Battery Leakage.....	36
7.2 On Fire.....	36
7.3 Wet Batteries	36

7.4 Damaged Batteries.....	36
8. Remarks	37
8.1 Recycle and Disposal.....	37
8.2 Maintenance	37
8.3 Declaration of conformity.....	37
9. Troubleshooting	37

Please read this manual before you install the battery and follow the instruction carefully during installation process. Electrical installation, maintenance must be performed by professional/qualified personnel. Please contact us immediately for advice and clarification if you have any question.

1. Symbol Description

	Do not place near open fire or flammable materials.
	A potential hazard exists when the equipment is working. Wear personal protective equipment during operation.
	Warning electric shock. Power off the equipment before any operation.
	Grounding: indicate PE cable connection position.
	Do not place in areas accessible to children.
	Keep the battery away from open fire or ignition sources.
	Please use the equipment reasonably. In extreme cases, the equipment may cause explosion risk.
	The equipment contains corrosive electrolyte. Please avoid contact with leaked electrolyte or volatile gas.
	Read the product and operation manual before operating the battery system.
	Label for Waste Electrical and Electronic Equipment (WEEE) Directive (2012/19/EU)
	The certificate label for CE.
	Recycle label.

2. Safety Precautions



Alert

- (1) It is important and necessary to read the user manual carefully (and attachment) before installing or using battery. Failure to do so or to follow any instruction or warning in this document can result in electrical shock, serious injury, and death, or damage battery, potentially rendering it unusable.
- (2) When battery is stored for a long time, it is required to charge once every 6 months, and the SOC should be no less than 85%.
- (3) After battery module cannot be discharged, it needs to be recharged within 12h.
- (4) Do not connect power terminal reversely.
- (5) All power supplies must be disconnected during maintenance.
- (6) Please contact the supplier within 24 hours if there is something abnormal.
- (7) Do not use any liquid to clean the battery.
- (8) Do not expose battery to flammable or irritating chemicals or vapor.
- (9) Do not paint any part of battery, including any internal or external components.
- (10) Do not connect battery with PV solar wiring directly.
- (11) Do not install or use this product beyond provisions of the manual.
- (12) Direct or indirect damages caused by the above reasons are not covered by warranty claim.



Warning

2.1 Before Connecting

- 1) Please check the external packaging condition before unpacking. If it is damaged, contact corresponding local retailer.
- 2) After unpacking, please check the products and spare parts according to spare parts list. If the product is damaged or missing, please contact your local retailer.
- 3) Connect to specified matching inverter.
- 4) Before installation, be sure to cut off the grid power and make SURE battery is in turned-off mode.
- 5) It is prohibited to connect the battery and AC power directly.
- 6) All electrical wiring must be connected in accordance with local regulations.
- 7) Please ensure that electrical performance of battery system is compatible with the equipment.
- 8) The installation onsite shall be equipped with fire-fighting facilities that meet relevant requirements, such as fire sand, dry powder fire extinguisher, etc.

2.2 In Using

- (1) If battery system needs to be moved or repaired, power must be cut off and battery is completely shut down.
- (2) Do not connect battery to faulty inverter.
- (3) In case of fire, only dry powder fire extinguisher can be used, liquid fire extinguishers are prohibited
- (4) Do not open, repair or disassemble the battery except Far East Battery personnel or other authorized personnel. The company shall not bear any liability or responsibility caused by violation of any safety operation or design standard, production standard, equipment safety standards or any other standards or requirements.

2.3 Storage and installation environment

- (1) Handle the product gently, prevent from dropping
- (2) Avoid open flame; keep away from flammables, explosives or corrosive chemicals
- (3) Choose cool and dry place for storage and installation
- (4) Prevent from water or humid intrusion
- (5) Prevent from accidental access (children and animals)
- (6) Do not step on the product packaging
- (7) Do not place any foreign objects on top of the battery pack
- (8) Do not store the battery pack upside down

2.4 Battery performance (based on cell temperature)

In order to achieve better battery life, the battery will have the following performance based on temperature and SOC during charging and discharging.

Charge

In the charging state, when $-10^{\circ}\text{C} < T \leq 0^{\circ}\text{C}$, the battery still runs for charging, but the charging current is small;

In the charging state, when $T > 0^{\circ}\text{C}$, the battery will adjust the charging current based on temperature and SOC status;

In the charging state, the high temperature protection is set to 55°C , and the battery will adjust the charging current according to the temperature and SOC status;

Discharge

When $-20^{\circ}\text{C} < T \leq 0^{\circ}\text{C}$, adjust the discharge current based on the battery SOC state ($\text{SOC} > 30\%$);

The high temperature protection is set to 55°C , and the battery will limit the discharging current according to the temperature and SOC status.

3. Introduction

NHS-1Y (10/15/20/25/30/35/40)K is a plug-in energy storage system consisting of battery module HV5120-S1-N and control box SHB1000PRO-N, which can provide reliable power supply for all kinds of equipment or systems. NHS-1Y

(10/15/20/25/30/35/40)K has built-in BMS battery management system, which can manage and monitor cells information including voltage, current and temperature.

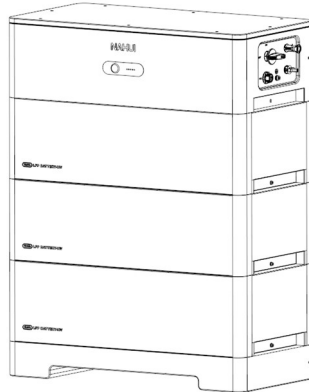

Figure 3-1

3.1 Features

- (1) Built-in soft-start function to reduce current impact.
- (2) When multiple modules are series connected, module addresses are set automatically.
- (3) Support for upgrading the battery module from the upper controller through CAN communication.
- (4) The module is non-toxic, non-polluting and environmentally friendly.
- (5) Cathode material is made from LiFePO₄ with safety performance and long cycle life.
- (6) Battery management system (BMS) has protection functions including over-discharge, over-charge, over-current and high/low temperature.
- (7) The system can automatically manage charge and discharge state and balance voltage of each cell.
- (8) Flexible configuration, multiple battery modules can be connected to expand capacity and power. Expandable to 10-40kwh (2-8 battery modules connected in series).
- (9) Adopted self-cooling mode rapidly reduced system entire noise
- (10) The module has less self-discharge, up to 6 months without charging it on shelf, excellent performance of shallow charge and discharge.

3.2 Specification

Parameters

No.	Items	Specification
1	Module Model	HV-5120-S1-N
2	Battery Type	LFP 1P32S
3	Total Capacity*1	5.12kWh
4	Rated Capacity*2	4.86kWh (95% DOD)
5	Nominal Voltage	102.4V
6	Working Voltage	91.2~115.2V
7	Charging Voltage	112V
8	Max. Charge Current*3	25A
9	Max. Discharge Current*4	40A
10	Communication	RS485 ,CAN,WiFi
11	Storage Temperature	0 ~ 45°C (Recommended)
12	Storage Humidity	≤85% (RH)
13	Working Temperature	Charging: -10°C~50°C*5 Discharging: -20°C~50°C
14	Working Humidity	≤95% (RH) No Condensation
15	Working Altitude	≤2000m
16	Ingress Protection	IP65
17	Protective Class	I
18	Weight	~44kg
19	Dimension(W*D*H)	636mm*330mm*188mm
20	Design Life	15 Years (25°C)
21	Cycle Life	>6000 (25°C,0.5C/1C,95%DOD)
22	Scalability	Module:2-8S, Up to 8 cabinets in parallel
23	Certification	IEC62619, IEC63056,CE EMC, UN38.3
24	Warranty	10 years

*1 Test conditions: cell voltage 2.0~3.65V, 25±2°C , 0.5C charge and 1C discharge.

*2 Test conditions: 95% depth of cell discharge ,25±2°C, 0.5C charge and 1C discharge.

*3 、*4 Depend on the temperature and SOC of battery.
 *5 Trickle charging at -10°C - 0°C , it is recommended to use at 0°C - 50°C

Dimensions

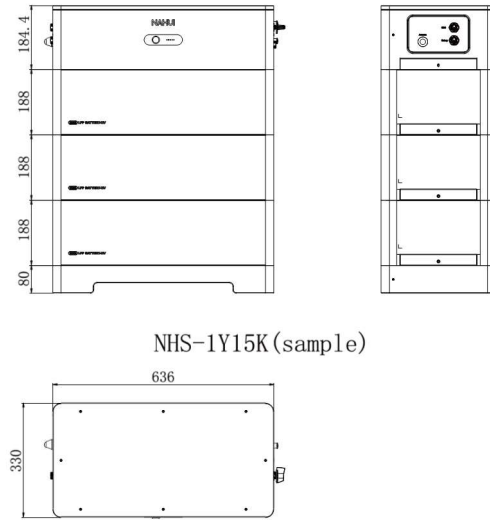

Figure 3-2

3.3 Equipment interface instruction

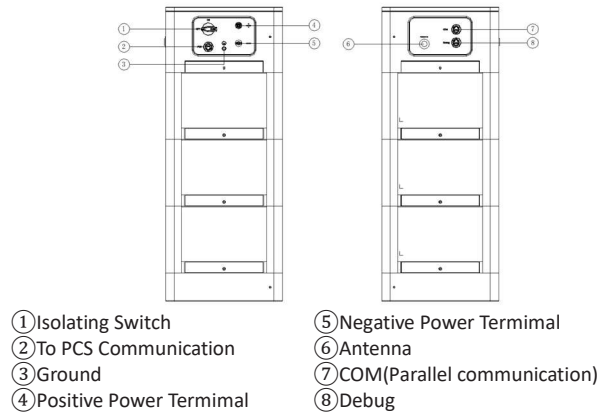

Figure 3-3

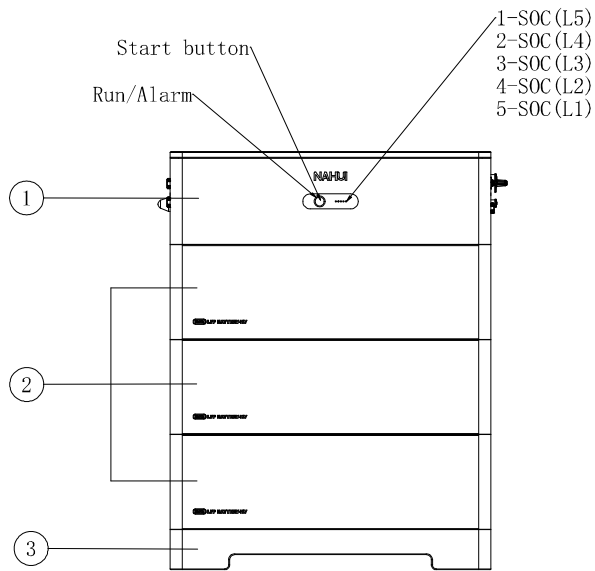

Figure 3-4

①Control module

②Battery module

③Mounting the base

3.4 Monitoring

Star



Turn on: When battery is dormant, press the START button to start the battery module.

Black start: When the PV and Grid are out Of power, press the START button for more than 10 seconds to start the battery to power the inverter, and the inverter adjusts the battery to power the load.

Run/Alarm

Blue LED lighting to show the battery system is running or having alarm.

Status	Mode	Run/Alarm	Remark
Power off	Power off		Light is off

Run	Standby/Charge/Discharge		Light is on
Alarm	Level I Alarm		System can run, but there will be alarm tips
	Level II Alarm		System will stop, and check the problem

NOTE:

Description of indicator light



The indicator light is off.



The indicator light is on

































The indicator light is flashing. Duration of indicator on is 0.25s, Duration of indicator off is 3.75s.



The indicator light is flashing. Duration of indicator on is 0.5s, Duration of indicator off is 1.5s.

SOC Indicator

Green LEDs are used to show the battery's remaining capacity.

State		Charging/Discharging				
Capacity Indicator LED		L5	L4	L3	L2	L1
SOC	0 ~ 20%					
	20 ~ 40%					
	40 ~ 60%					
	60 ~ 80%					
	80 ~ 95%					
	95 ~ 100%					

NOTE:



The SOC indicator light is off.



The SOC indicator light is on.



The SOC indicator light is flashing, Duration of indicator on is 0.5s, Duration of indicator off is 0.5s.

Isolating Switch

When you rotate the Isolating Switch to ON position, Positive Power Terminal will connect with the HV+ battery contactor and Negative Power Terminal will connect with the battery HV-, on the other hand, when Isolating Switch is at OFF position both connection will off.

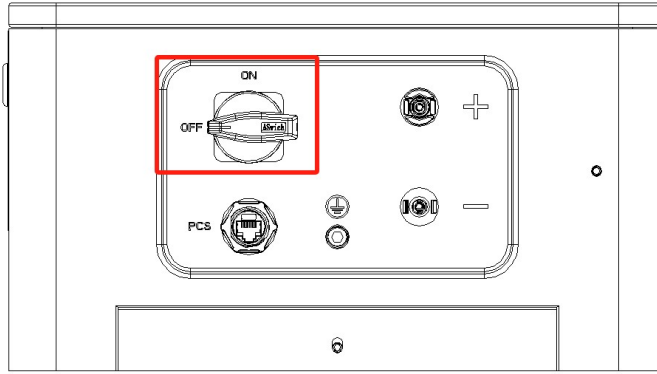

Figure 3-5

Power Terminal

Power cable terminals: There are two pairs of terminals with the same function, which are respectively connected to the inverter and battery module

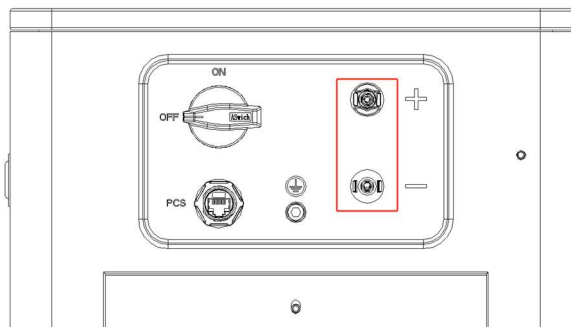

Figure 3-6

Ground

The recommended grounding cable specifications are as follows.

Ground cable	10AWG (yellow-green)
Ring termina	M6
Screw	M6

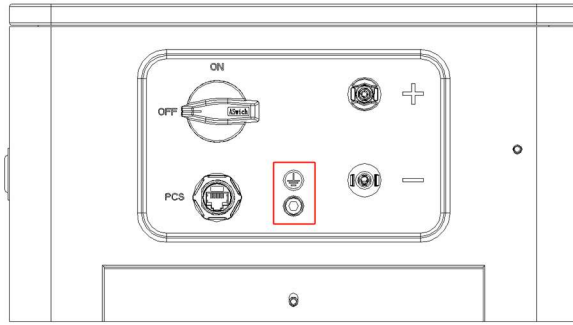

Figure 3-7

PCS

Be used to communicate with inverter or upper battery.

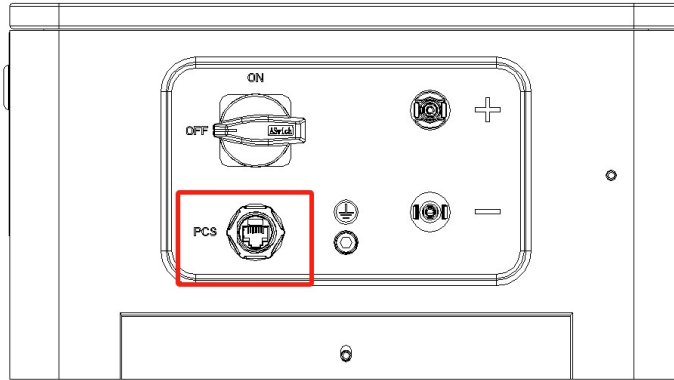
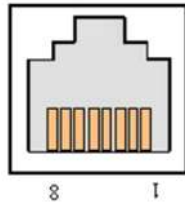

Figure 3-8

RJ45 Socket



Pin	Definition
1	RS485-1A
2	RS485-1B
3	Undefined
4	CAN3-H

5	CAN3-L
6	Undefined
7	/
8	/

Communication with PCS by RS485.(RS485-1A RS485-1B)

CAN3: Communication with PCS by CAN

COM

CAN communication port with computer.

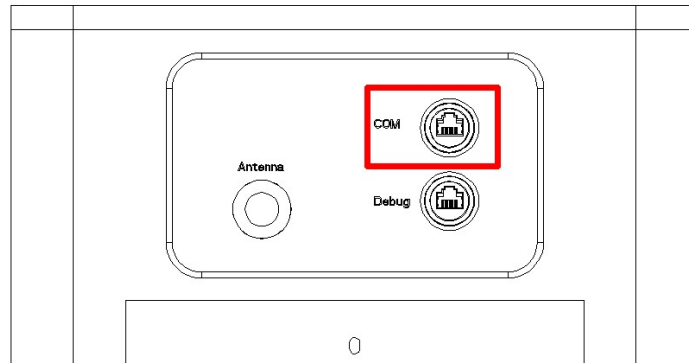
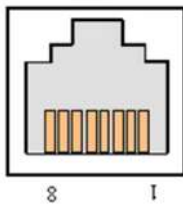

Figure 3-9

RJ45 Socket



Pin	Definition
1	24V-
2	ADDR_DO
3	Undefined
4	Undefined
5	Undefined
6	Undefined
7	CAN2H
8	CAN2L

CAN communication: CAN bus for each rack and upper computer. (CAN2H CAH2L).

Debug

For battery debug usage.

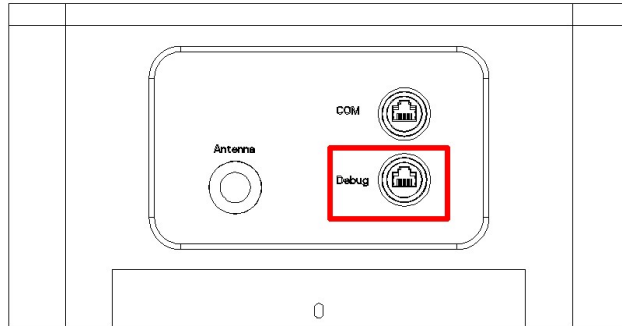
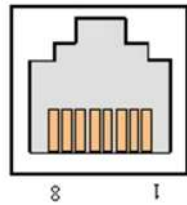

Figure 3-9

RJ45 Socket



Pin	Definition
1	24V-
2	ADDR_DI
3	Master Address DI
4	RS485-2B
5	RS485-2A
6	24V+
7	CAN2H
8	CAN2L

24V-: DC Input (Pin1connect with 24V-).

RS485-2: communication: RS485 for each rack and upper computer or display monitor (RS485-2A RS485-2B).

24V+: DC Input (Pin6 connect with 24V).

4. Safe Handling of Lithium-iron ESS Batteries Guide

4.1 Solution Diagram

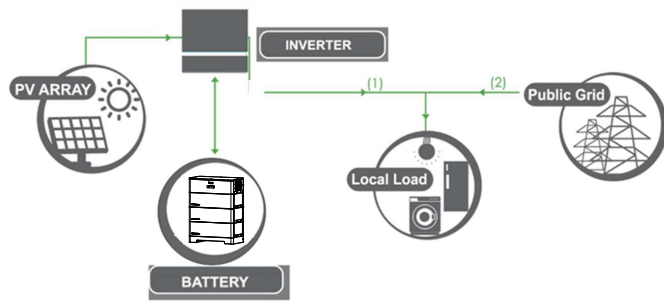

Figure 4-1

4.2 Danger Label

WARNING
 DANGER HIGH DC VOLTAGE INSIDE
 DANGER ARC FLASH & SHOCK HAZARD

- *Do not disconnect or disassemble by non-professional personnel.
- *Do not drop, deform, impact, cut or spear with sharp objects.
- *Do not place near open flame or flammable materials.
- *Do not cover or wrap the product case.
- *Do not come into contact with liquids.
- *Be aware of high temperature.
- *Avoid direct sunlight.
- *Follow the product manual for wire connection.
- *If any leakage, fire, wet or damage occur, switch off the breaker on DC side and stay away from the battery.
- *Contact the supplier within 24 hours if failure occurs.

Figure 4-2

4.3 Tool



Wire Cutter



Modular
Crimping Plier



Screwdriver



Electric drill

NOTE:

Properly use insulated tools to prevent accidental electric shock or short circuits. If insulated tools are not available, cover the entire exposed metal surfaces of the available tools, except their tips, with electrical tape.

4.4 Safety Gear

It is recommended to wear the following safety gear when dealing with battery pack.



Insulated Gloves



Safety Goggles



Safety Shoes

5. Installation and operation

5.1 Package items

Unpacking and check the Package items

- 1) For battery module package:
 - Battery Module
- 2) For packing box of high voltage box:

NOTE: Power and communication cables connect to inverter belongs to the packing box of high voltage box.

- 2 * 2000mm 8AWG power cables
- 1*3000mm RJ45 communication cable for communication with inverter
- 1*3000mm RJ45 communication cable for paralleling communication between battery clusters
- 1 * 3000mm 10AWG grounding cable
- 1*70mm Termination resistor harness

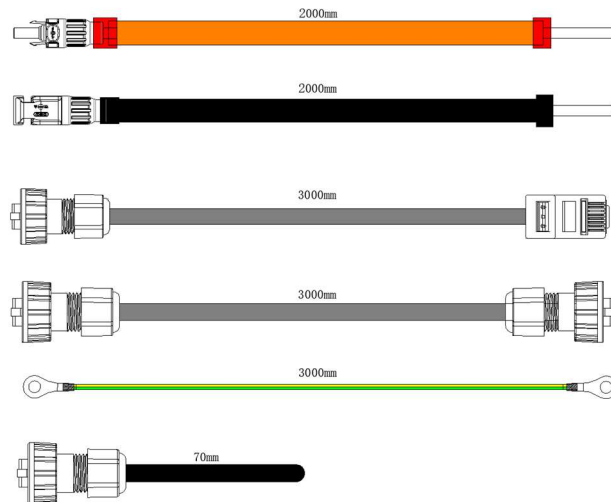

Figure 5-1

5.2 Installation Location

Make sure that installation location should meet the following condition:

- (1) The area should be completely water-proof.
- (2) The floor should be flat and level.
- (3) No flammable or explosive materials.
- (4) The ambient temperature is within the range from 0°C to 45°C.
- (5) The temperature and humidity are maintained at a constant level.
- (6) There is just a little dust and dirt in the area.
- (7) The distance from heat source should be more than 2 meters.
- (8) The distance from air outlet of inverter is more than 0.5 meters.
- (9) Installation areas should avoid direct sunlight.
- (10) No forced ventilation requirement for battery module, but please avoid installing in a closed area. Ventilation shall avoid high salinity $\leq 30\%$, humidity $\leq 85\%$ and ambient temperature of 0 ~ 45 °C.

5.3 Installation Direction

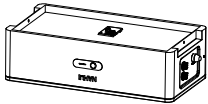
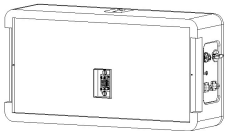
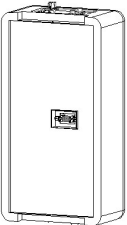
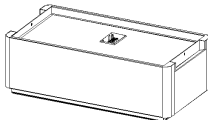
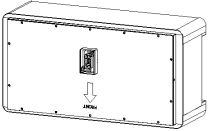
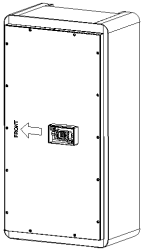

Warning

Upside down	Sidelong	Sidelong
		
		

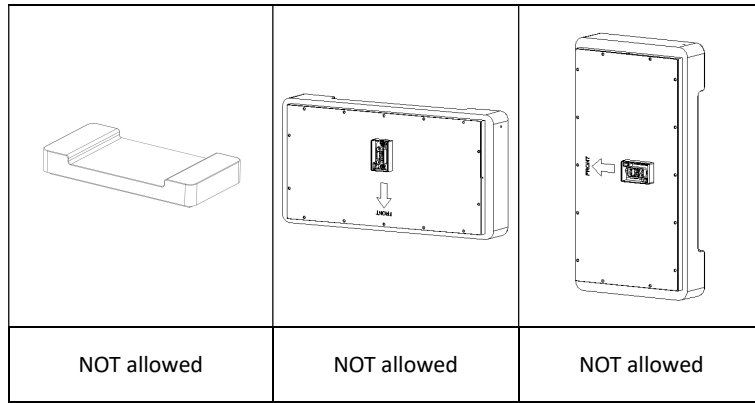

Figure 5-2

5.4 Installation Clearances and Angle

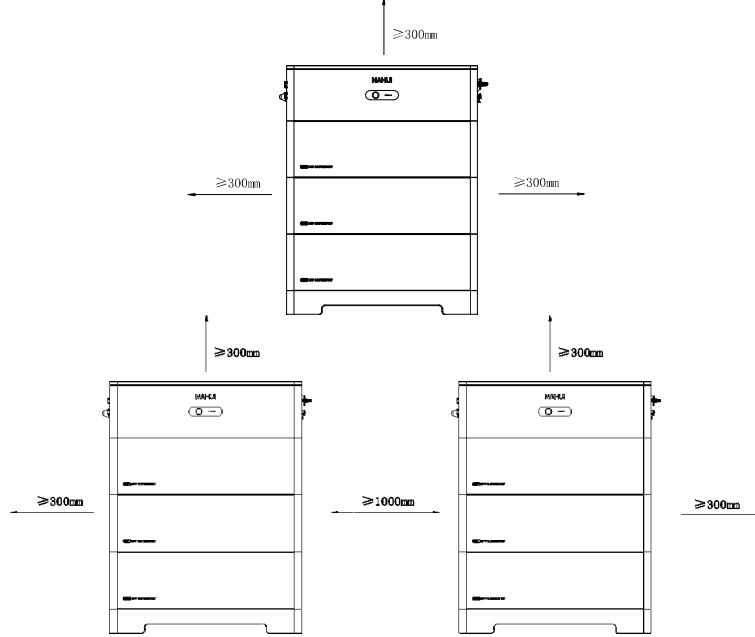

Figure 5-3

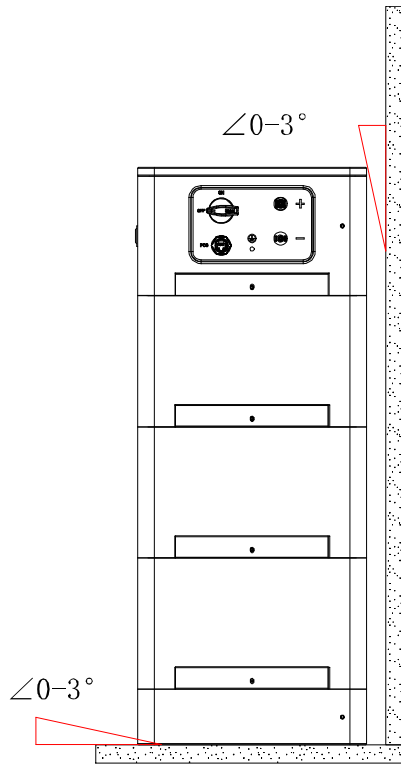

Figure 5-4

5.5 Installation Steps



Warning

- 1) Follow local electric safety and installation policy, a suitable breaker between battery system and inverter is required.
- 2) All installation and operation must follow local electric standard and requirements.
- 3) When battery modules are paralleled, the system should be powered off before installation operation

1. Install the brackets to the base of the battery rack using 2 pcs M4*10 socket head cap screws with locking torque of 2.5N•m.

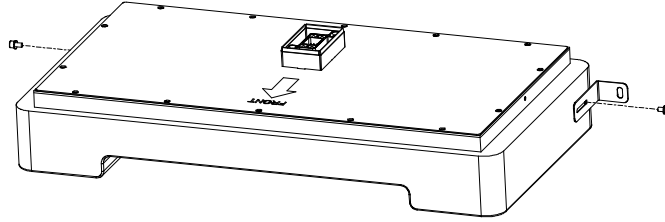

Figure 5-5

2. Install the brackets to the HV Box of the battery rack using 2 pcs M4*10 socket head cap screws with locking torque of 2.5N•m.

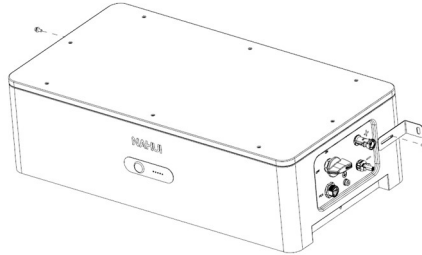

Figure 5-6

3. Place the base against the wall and mark the position of mounting holes on the wall. Remove the base and drill holes using an electric drill. The electric drill must with a dust cover to prevent dust from falling off.

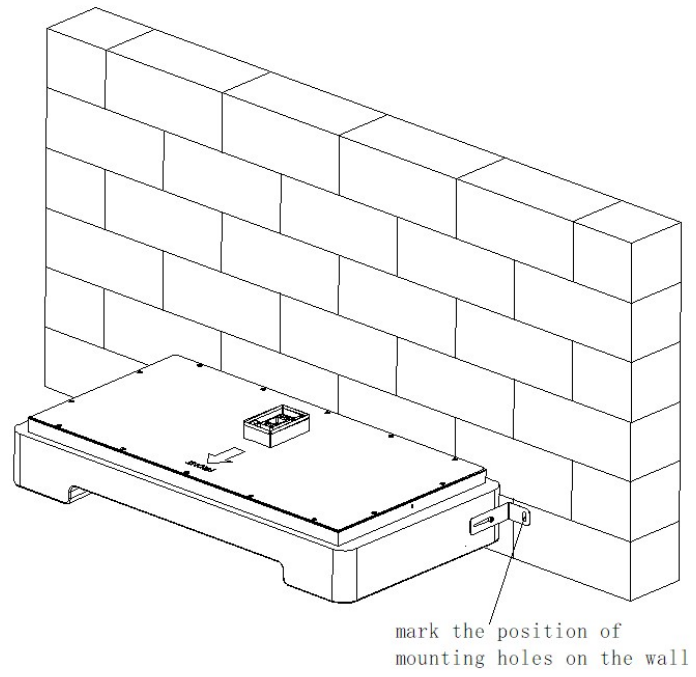

Figure 5-7



Figure 5-8

4. Place the base against the wall and fix the base to the wall with position of mounting holes on the wall with 2 pcs M6 expansion screws by 8N•m.

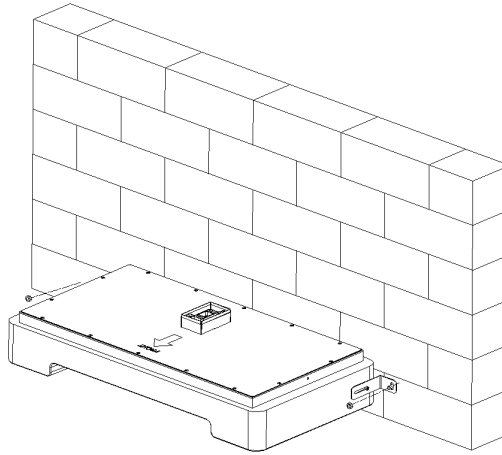

Figure 5-9

5. Then lay the battery module one by one on the base, and fix all the M4*8 sunk screws on the left side and right side (each module have 4 fixed point)by 2N•m.

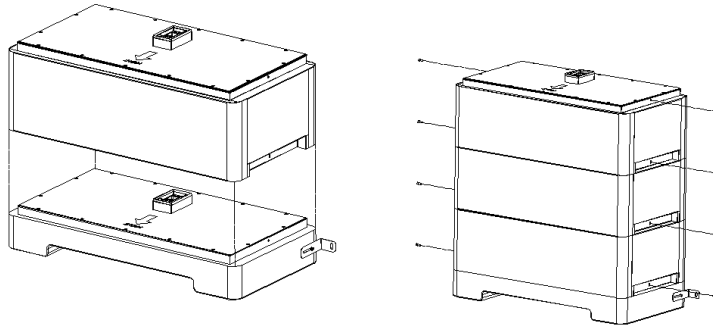

Figure 5-10

6. Place the HV box on the top of the module and mark the position of mounting holes on the wall. Remove the HV box and put a dust cover over the top of the module and then drill holes using an electric drill to prevent dust from falling off. Place the HV box back and fix the base to the wall with position of mounting holes on the wall with 2 pcs M6 expansion screws by 8N•m.

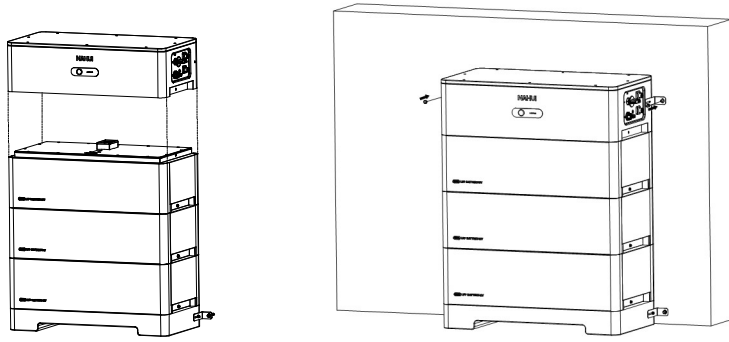

Figure 5-11

7. Power Connector Installation

1. Connect the power plug to the control module, and push it until you hear a “ Click” sound which proves the fastened connection(Figure5-12).

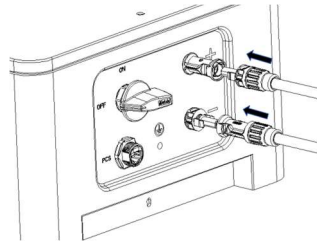
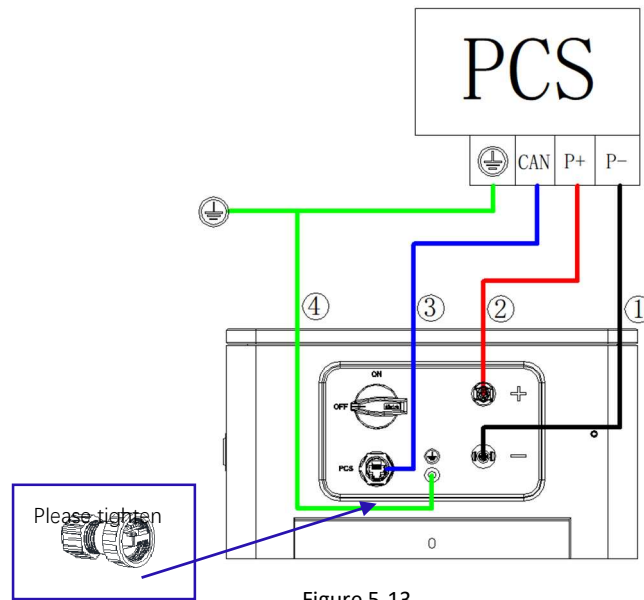

Figure 5-12

8. Cable Connect



	Harness name
①	B-harness
②	B+harness
③	CAN communication cable
④	Ground cable (M6 Hexagon socket head cap screws, Torque: 5N±0.5)



Figure 5-14

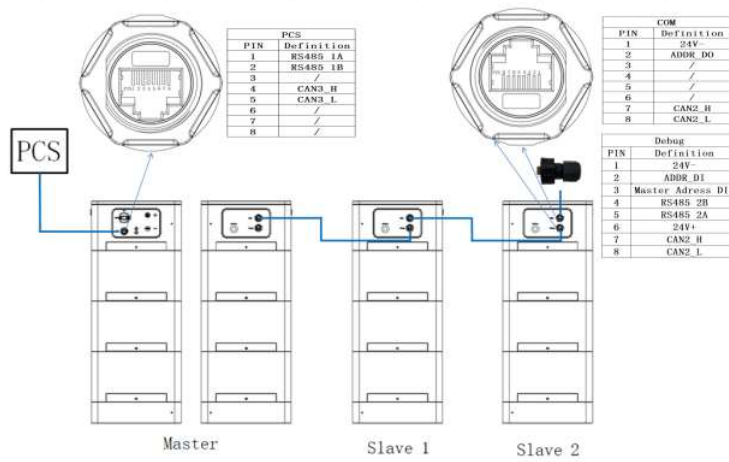

Figure 5-15

9. Parallel connection procedures

- 1) Be sure that each battery cluster is switched off, namely air switch of each battery cluster is "OFF".
- 2) Power output+ of each battery connect to inverter BAT+, and power output- connect to inverter BAT- as per Figure 5-14, and the Ground cable connect Ground port.
- 3) As for communication connection, please refer to the Figure 5-15: left cluster COM port connect to right cluster DEBUG port, and the last left cluster COM port connect with a RJ45 male connector.
- 4)The left battery cluster PCS port connect to inverter communication port.
- 5)Turn on battery clusters one by one right-to-left (turn air switches "ON" then press the front start button for each battery cluster).
- 6)If the left battery communicates with inverter normally, the parallel procedure will be done.

NOTE: The com port is not connected to the termination resistor when used in a single cluster; the com port is connected to the termination resistor when multiple clusters are in parallel.

5.6 System turns on

Warning: Double check all the power cables and communication cables. Make sure the voltage of the inverter/PCS is same level with the battery system before connection. Check all the power switches are OFF.

System turns on step:

- 1)Check all cables are connected correctly. Check grounding is connected.
- 2)If necessary, turn on the switch at inverter's battery side or between inverter and battery. If possible, turn on AC or PV power source to wake up

inverter.

3) Open protect cover of Power switch. And turn on power switch.

4) Switch all the battery racks' Isolating Switch to on position.

5) Press the battery START button in turn, turn on the START metal button of the slave battery firstly, and finally turn on the START button of the master battery (1 master battery rack and 7 slave battery racks at most can be configured).

6) If no alarm, the battery system will be ready for charging and discharge with PCS.

5.7 System turns off

When failure or before service, must turn the battery storage system off:

1) Turn off inverter or power supply on DC side.

2) Turn off the switch between PCS and battery system.

3) Switch Isolating Switch to off position. (Switch off the slave battery firstly, finally switch off the master battery)

NOTE:

1) One battery system shall just have one master, all the others are slaves. (The one on the extreme side connected to inverter is the master battery.)

2) It is forbidden to switch off the Isolating Switch during charging and discharging.

6. iErgon APP

6.1 Overview

iErgon APP is a mobile app that can communicate with the Battery through WiFi or Bluetooth. The following are commonly used functions:

- 1) Monitor system data, alarm information, software version of the equipment.
- 2) Set the parameters of the Battery.
- 3) Maintain the equipment.

When installing the device, you need to initialize your APP according to the following steps:

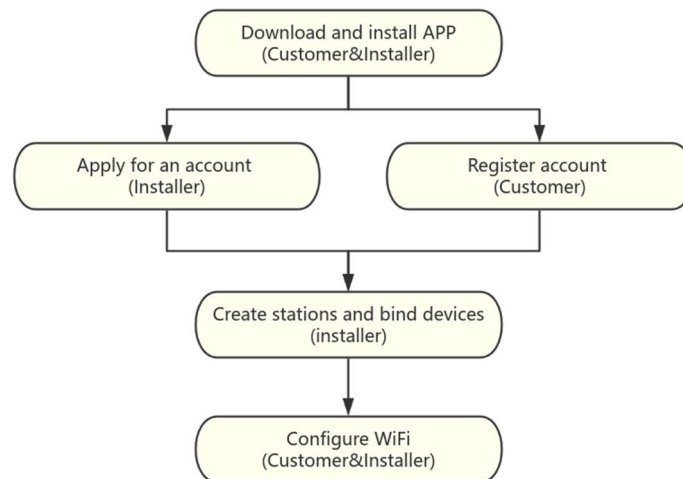

6.2 Download and install APP (Customer&Installer)

Search for the [iErgon](#) APP in Google Play (Android) or APP Store (IOS), download and install it.

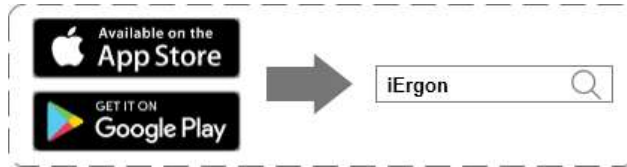

6.3 Apply for an account (Installer)

Installer need to apply for an account with the manufacturer or the superior agent.

- **steps**

- 1) Apply for an account;
- 2) Choose the account type <Agent> on the login page, and enter the account obtained in step 1 to log in;

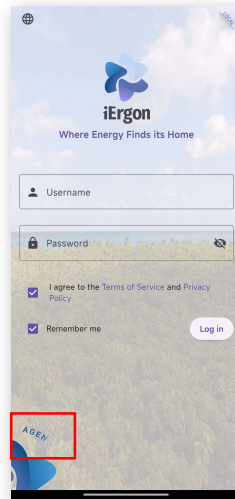

6.4 Register account (Customer)

The registration function is provided for end users and is one of the necessary steps for device activation to the platform.

- **steps**

- 3) Choose the account type <Customer> on the login page;

- 4) Click [Sign up now](#) at the bottom of the login page;
- 5) Enter [name](#), [date of birth](#), [email](#), and [phone number](#) in order;
- 6) Confirm your email on the final confirmation page, and click [Sign in now](#);
- 7) The platform will send a confirmation email to your email within 24 hours, click [Active Your Account](#) in the email to open the password setting page;
- 8) Set your password in the password setting page. If registration is successful, a prompt will be displayed: "User has been successfully activated!".

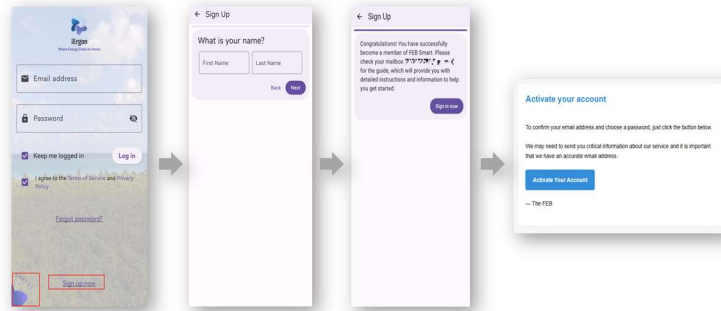

6.5 Create Stations and bind devices (Installer)

Creating stations and binding devices is one of the necessary steps for device installation. After completion, customers can view these stations and devices.

- **steps**

- 1) Click the Create button on the station list page to open the Create Station page.
- 2) On the page of creating station, Fill in the information and create (Please fill in the email of the customer who owns this station);
- 3) Find the created station in the station list and click;
- 4) On the page of station, click the [Add New Device](#) button and scan the [bar code](#) on the device body to bind the device;

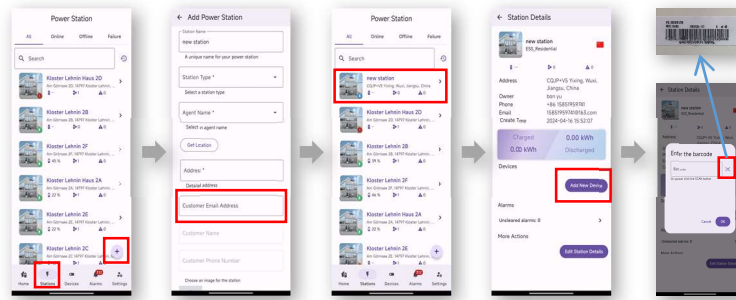

6.6 Configure WiFi (Customer&Installer)

Configuring one of the necessary steps for device installation, before WiFi configuration, it is necessary to ensure that 2.4GHz Wi-Fi is available nearby (generally, if a router has 5GHz Wi-Fi, it must have 2.4GHz Wi-Fi. If 2.4GHz Wi-Fi is turned off, it needs to be turned on the router).

- **steps**

- 1) Make sure that the device is turned on normally;
- 2) Find the device in the device list and click;
- 3) On the page of device, click the more button to the right of the title;
- 4) Click the WiFi Provisioning button to complete the WiFi configuration;
- 5) After the WiFi configuration is successful, the device will be displayed as **online**;

Note: If the device has been configured with a network, it will not be able to connect to the Bluetooth of the device after 1 minute; if the connection is unsuccessful for a long time, please restart the device and try to connect again within 1 minute.

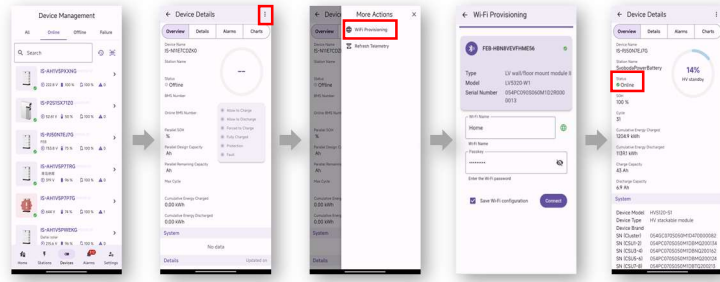

7. Emergency Situations

7.1 Battery Leakage

If the battery pack leaks electrolyte, avoid contact with the leaking liquid or gas. If one is exposed to the leaked substance, immediately perform the actions described below

- 1) Inhalation: Evacuate contaminated area and seek medical aid.
 - 2) Contact with eyes: Rinse eyes with flowing water for 15 minutes and seek medical aid.
 - 3) Contact with skin: Wash affected area thoroughly with soap water and seek medical aid. Ingestion: Induce vomiting and seek medical aid.
- Ingestion: Induce vomiting and seek medical aid.

7.2 On Fire

Only dry powder fire or carbon dioxide extinguisher can be used; if possible, move the battery module to a safe area before it catches fire.

7.3 Wet Batteries

If the module is wet or submerged in water, do not let people access it, then contact NAHUI or an authorized dealer for technical support. Cut off all power switch on inverter side.

7.4 Damaged Batteries

Damaged batteries are dangerous and must be handled with utmost care. They are not fit for use and may pose a danger to people or property. If the module seems to be damaged, pack it in its original container, then return it to authorized dealer.



Warning

Damaged batteries may leak electrolyte or produce flammable gas.

8. Remarks

8.1 Recycle and Disposal

In case a battery (normal condition or damaged) needs disposal or needs recycling, it shall follow the local recycling regulation (i.e. Regulation (EC) N^o 1013/2006 among European Union) to process, and using the best available techniques to achieve a relevant recycling efficiency.

8.2 Maintenance

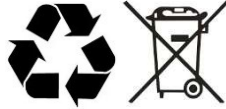

- 1) It is required to charge the battery at least once every 6 months, for this charge maintenance make sure the SOC is charged to higher than 85%.
- 2) Check installation environment such as dust, water, insect etc. Make sure it is suitable for IP20 battery system. Connection of power connector, grounding point, power cable and screw are suggested to be checked every year

8.3 Declaration of conformity

The battery system described in this document complies with the applicable European directives. The certificate is available in the download area of our websites.

9. Troubleshooting

users can understand the fault status of the battery through indicator lights or monitoring software. Once the user knows the fault Phenomenon, refer to the following sections for solutions.

Fault Phenomenon	Cause	Solution
Button startup failed	The BMS is not activated by the button, and the battery cannot be turned on	1. Make sure the disconnecter is at ON position. 2. Check the status of buttons and cables. 3. Start up and check the BMS status through monitoring software. 3. If there is a hardware malfunction, please contact the local engineer.
No HV output	BMS and PCS communication fault	1. Make sure the communication cable connection is correct and contact. 2. Make sure the PCS protocol and other settings are correct. 3. If there is a hardware malfunction like the fuse and contactor, please contact the local engineer.
Charging/discharging Over Temperature Protection	The cell temperature is higher than the cell temperature protection value.	1. Install the battery in the allowed temperature environment. 2. Restart after 1 hour of system shutdown
Charging/discharging Under Temperature Protection	The ambient temperature is too low, causing the cell temperature to be lower than the minimum allowable temperature.	1. Install the battery in the allowed temperature environment. 2. When the temperature of the battery cell exceeds the threshold, turn on the system.
Ambient Over Temperature Protection	The ambient temperature of the battery is higher than the maximum allowable temperature of the system	1. Please shutdown the system. 2. Restart after 1 hour. 3. If the malfunction occurs again, please contact the local engineer.
Ambient Under Temperature Protection	The ambient temperature of the battery is lower than the maximum allowable temperature of the system	1. Please install the battery in the allowed temperature environment according to the user manual
Charging/discharging Over Current Protection	Due to load or hardware reasons, the charging and discharging current is above the threshold.	1. Restart the inverter to see if the fault still exists. If it still exists, please contact the local engineer.
Charging Over Voltage Protection	Cell or battery voltage above threshold.	1. Shut down the system 2. Measure the battery port voltage and the BMS detection voltage to be the same. 3. If the fault cannot be eliminated after 1 hour, please contact the local engineer.
Discharging Under Voltage Protection	Cell or battery voltage below threshold	1. Please charge immediately until the fault disappears. 2. If the fault occurs frequently, please contact the local engineer.
Internal Fault	System production line hardware failure, unable to charge and discharge	1. Check if the internal communication cable. 2. Check BMS for any errors. 3. Check if the sampling line of the battery cell. 4. If the fault cannot be eliminated, please contact the local engineer.
Excessive voltage difference	The voltage difference between battery cells is greater than the threshold	1. Measure the actual voltage of the battery cell through an instrument. 2. Battery damage, please contact the local engineer.
Low Battery	Battery level below threshold due to prolonged standby or discharge	1. Please charge immediately until the fault disappears.

This manual may be updated according to user's or customer's feedback. The information in this manual is subject to change without notice. The latest user manual can be downloaded from the official website by scanning the QR code or entering website at <https://www.nahui-newenergy.com> for latest version. Please adhere to the actual products in case of any discrepancies in this user manual. If you encounter any problem on the battery, please find out the battery S/N and contact us, we will try to respond to your question ASAP.



Qingdao Nahui Energy Technology CO.,LTD
Address:Room303,Entrance1 NO.4Building
Lan Gu Entrepreneurship Center Phase1 NO.7,Keji Yilu Road,
Aoshanwei Sub district Office, Jimo District Office, Jimo District,
Qingdao, Shandong
web:www.nahui—newenergy.com